

REVISION
 03/01/03
 11/24/03
 04/16/08
 MB

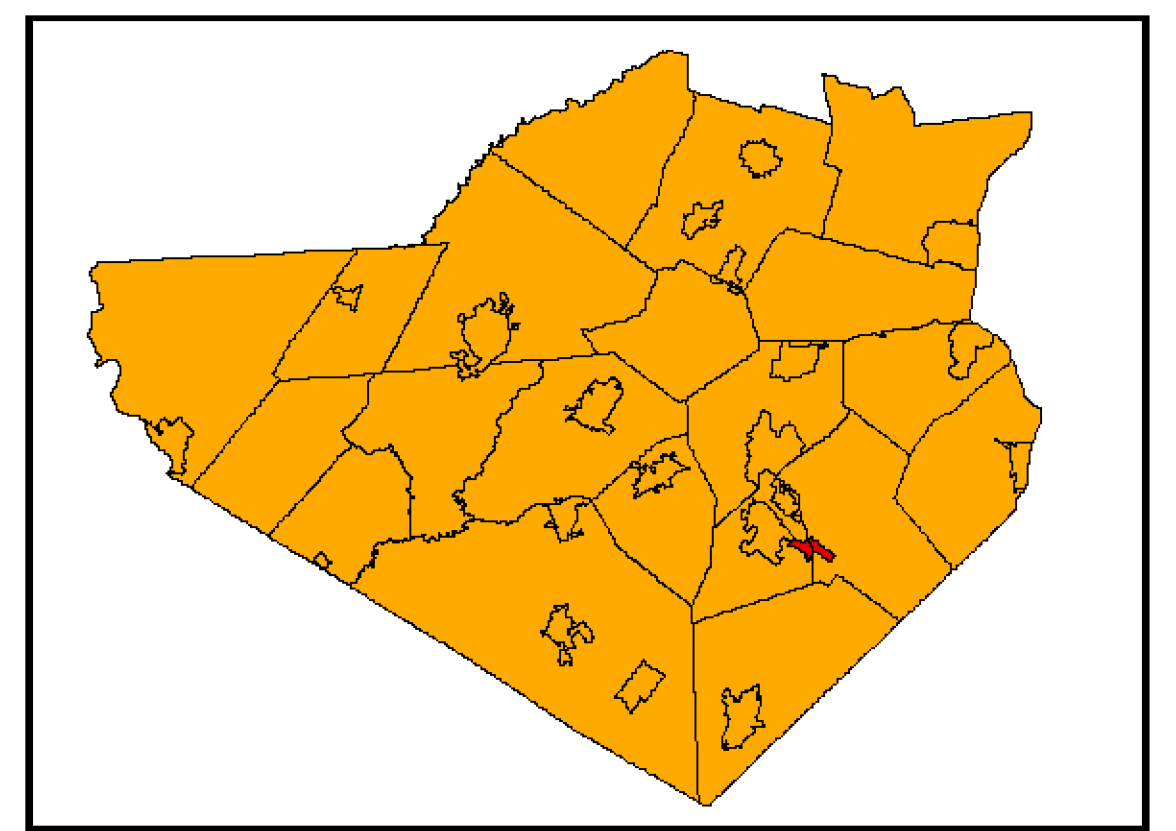

Vicinity HARRIMAN VICINITY MAP

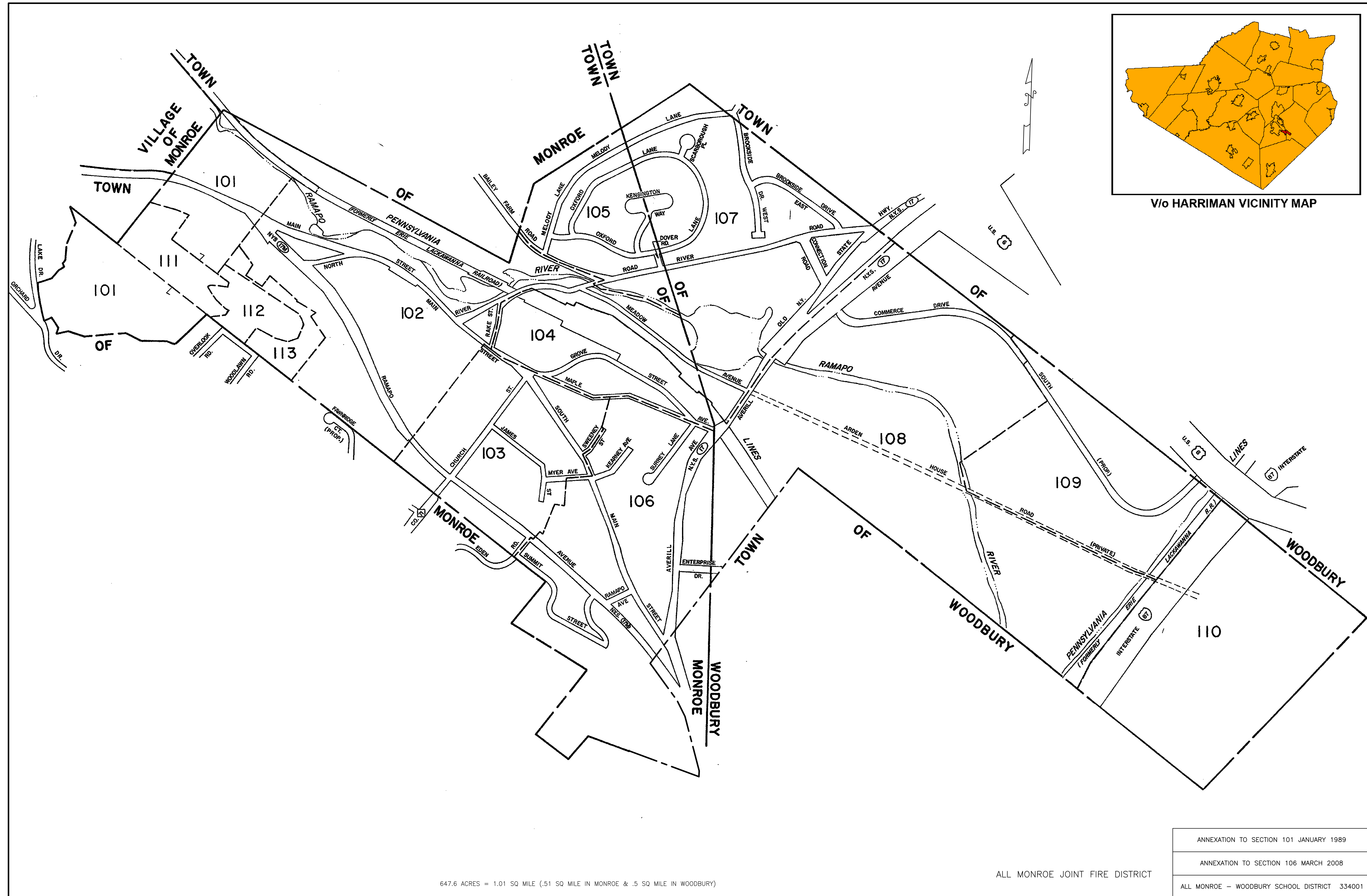

647.6 ACRES = 1.01 SQ MILE (.51 SQ MILE IN MONROE & .5 SQ MILE IN WOODBURY)

ALL MONROE JOINT FIRE DISTRICT

ANNEXATION TO SECTION 101 JANUARY 1989
ANNEXATION TO SECTION 106 MARCH 2008
ALL MONROE - WOODBURY SCHOOL DISTRICT 334001

LEGEND			
STATE OR COUNTY LINE	FILED PLAN LOT LINE	TAX MAP BLOCK NO. (4)	FILED PLAN BLOCK NO. (2) (4)
CITY TOWN OR VILLAGE	EASEMENT LINE	TAX MAP PARCEL NO. 32	FILED PLAN LOT NO. (3) or (P/o 2)
BLOCK OR SECTION LIMIT	MATCH LINE	AREAS (DEED) 11.1A or (CALCULATED) 11.6(C)	STATE HIGHWAYS N Y STATE HWY NO 17
SPECIAL DISTRICT LINE	WATER FEATURES	DIMENSIONS (DEED) 66 or (CALCULATED) 75S	COUNTY HIGHWAYS COUNTY ROAD NO 4
PROPERTY LINE	GRID COORDINATE/CENTROID	PORTION OF TAX LOT P/o 1-1-1	TOWN ROADS TOWN ROAD 1

ORANGE COUNTY-NEW YORK

Prepared by
 Orange County Tax Map Department
 124 Main Street, Goshen, N.Y. 10924
 Phone 845.291.2498 Fax 845.291.2499

NOTICE
 MAINTENANCE, ALTERATION, SALE OR DISTRIBUTION
 OF ANY PORTION OF THE ORANGE COUNTY TAX
 MAP IS PROHIBITED WITHOUT WRITTEN PERMISSION
 OF THE O.C. REAL PROPERTY TAX SERVICE AGENCY



334003
VILLAGE OF HARRIMAN
 334003 (IN TOWN OF MONROE)
 335801 (IN TOWN OF WOODBURY)
 Scale 1" = 400' Section No. **KEY MAP**
 AND 13 SECTIONS

REVISION
03/01/03
10/22/03
04/24/08
MJK
04/25/08
LR
08/21/09
LR

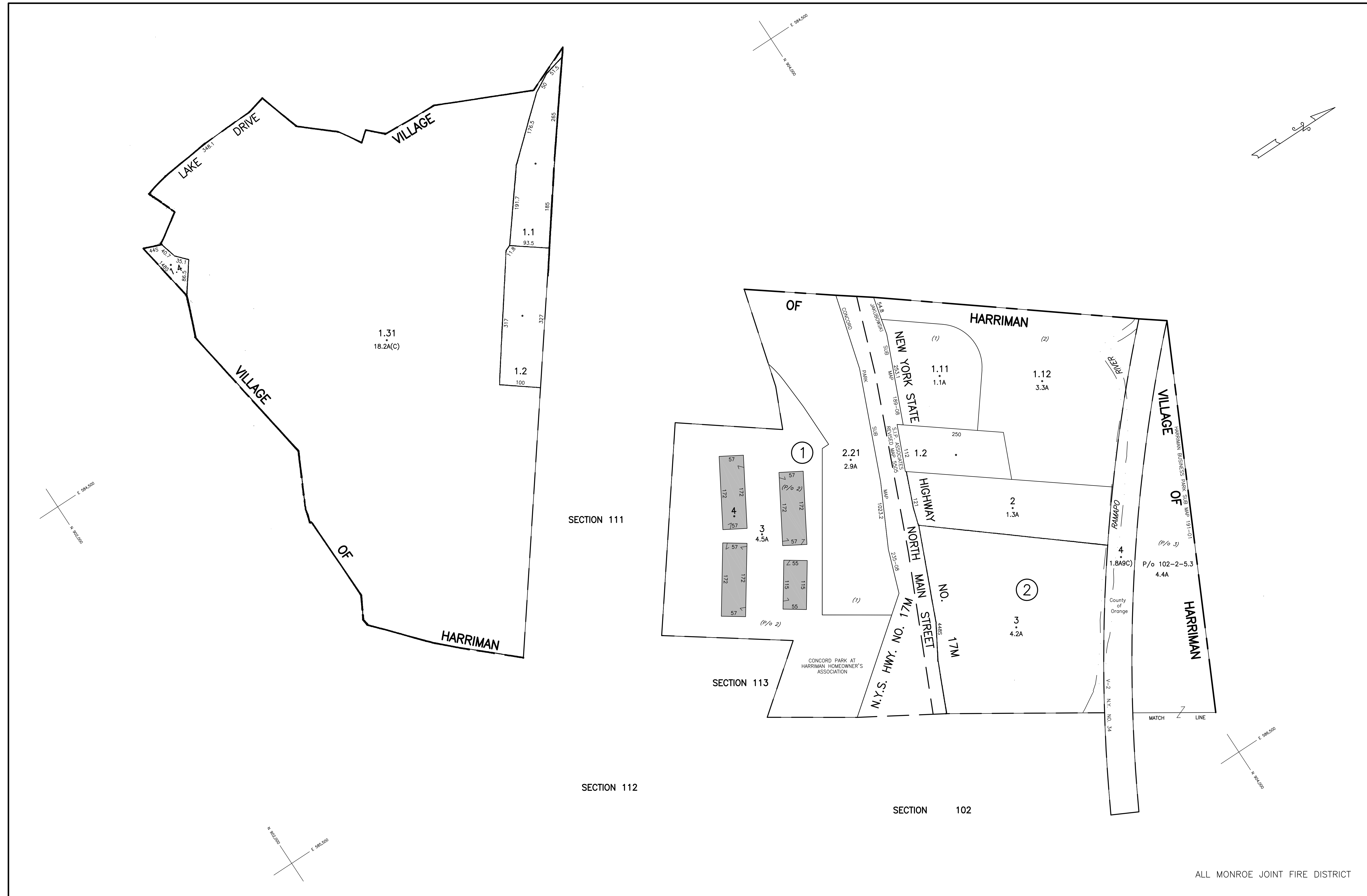

ALL MONROE JOINT FIRE DISTRICT

LEGEND			
STATE OR COUNTY LINE	FILED PLAN LOT LINE	TAX MAP BLOCK NO. (4)	FILED PLAN BLOCK NO. (2) (4)
CITY TOWN OR VILLAGE	EASEMENT LINE	TAX MAP PARCEL NO. 32	FILED PLAN LOT NO. (3) or (P/o 2)
BLOCK OR SECTION LIMIT	MATCH LINE	AREAS (DEED) 11.1A or (CALCULATED) 11.6A(C)	STATE HIGHWAYS N Y STATE HWY NO 17
SPECIAL DISTRICT LINE	WATER FEATURES	DIMENSIONS (DEED) 66 or (CALCULATED) 75S	COUNTY HIGHWAYS COUNTY ROAD NO 4
PROPERTY LINE	GRID COORDINATE/CENTROID	PORTION OF TAX LOT P/o 1-1-1	TOWN ROADS TOWN ROAD 1

ORANGE COUNTY—NEW YORK

Prepared by
Orange County Tax Map Department
124 Main Street, Goshen, N.Y. 10924
Phone 845.291.2498 Fax 845.291.2499

NOTICE
MAINTENANCE, ALTERATION, SALE OR DISTRIBUTION
OF ANY PORTION OF THE ORANGE COUNTY TAX
MAP IS PROHIBITED WITHOUT WRITTEN PERMISSION
OF THE O.C. REAL PROPERTY TAX SERVICE AGENCY

NOT TO BE REPRODUCED FOR COMMERCIAL
PURPOSES FOR TAX PURPOSES ONLY
NOT TO BE USED FOR CONVEYANCE

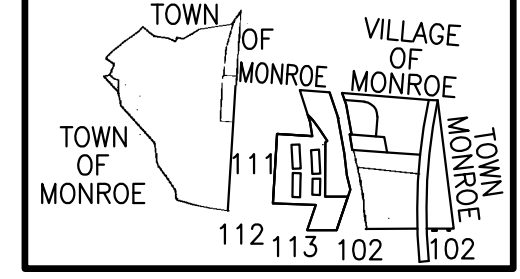

334003
VILLAGE OF HARRIMAN

Scale 1" = 100' Section No. 101

ADJOINING REFERENCE

REVISION
03/01/03
01/29/04
03/06/06
05/18/06
07/19/06
10/30/06
04/27/07
05/14/10
LR

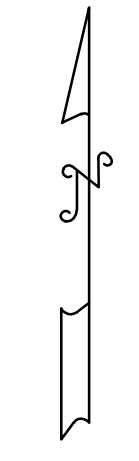
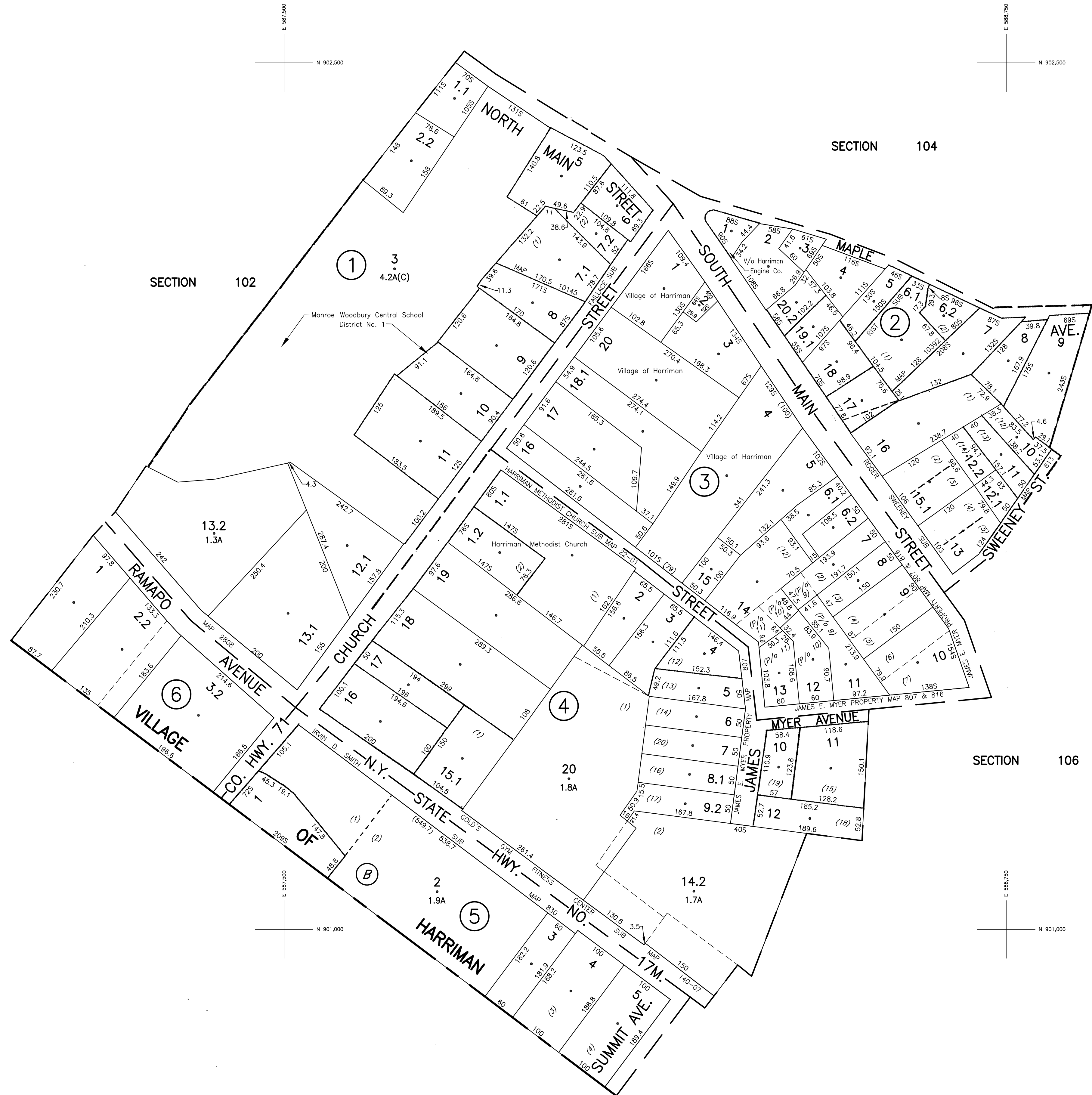

ALL MONROE JOINT FIRE DISTRICT

LEGEND

STATE OR COUNTY LINE	FILED PLAN LOT LINE	TAX MAP BLOCK NO. (4)	FILED PLAN BLOCK NO. (2) (4)
CITY TOWN OR VILLAGE	EASEMENT LINE	TAX MAP PARCEL NO. 32	FILED PLAN LOT NO. (3) or (P/o 2)
BLOCK OR SECTION LIMIT	MATCH LINE	AREAS (DEED) 11.1A or (CALCULATED) 11.6(C)	STATE HIGHWAYS N Y STATE HWY NO 17
SPECIAL DISTRICT LINE	WATER FEATURES	DIMENSIONS (DEED) 66 or (CALCULATED) 75S	COUNTY HIGHWAYS COUNTY ROAD NO 4
PROPERTY LINE	GRID COORDINATE/CENTROID	PORTION OF TAX LOT P/o 1-1-1	TOWN ROADS TOWN ROAD 1

ORANGE COUNTY-NEW YORK

Prepared by
Orange County Tax Map Department
124 Main Street, Goshen, N.Y. 10924
Phone 845.291.2498 Fax 845.291.2499

NOTICE
MAINTENANCE, ALTERATION, SALE OR DISTRIBUTION
OF ANY PORTION OF THE ORANGE COUNTY TAX
MAP IS PROHIBITED WITHOUT WRITTEN PERMISSION
OF THE O.C. REAL PROPERTY TAX SERVICE AGENCY

NOT TO BE REPRODUCED FOR COMMERCIAL
PURPOSES FOR TAX PURPOSES ONLY
NOT TO BE USED FOR CONVEYANCE

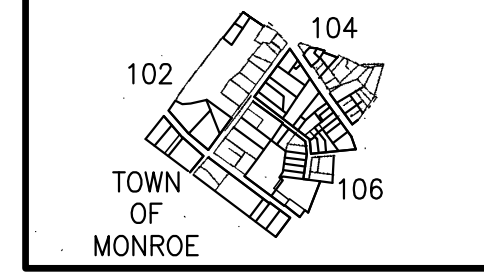

334003
VILLAGE OF HARRIMAN

Scale 1" = 100' Section No. 103

REVISION
03/01/03
10/22/03
02/06/04
02/09/06
LR
11/13/09
m.a.w.

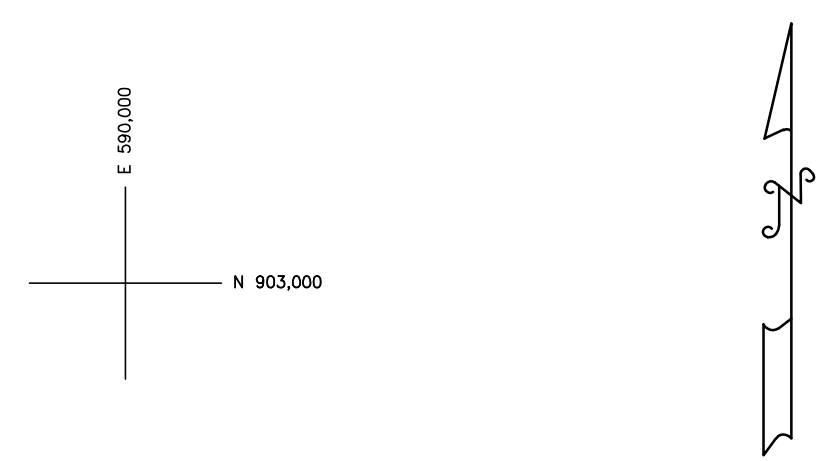
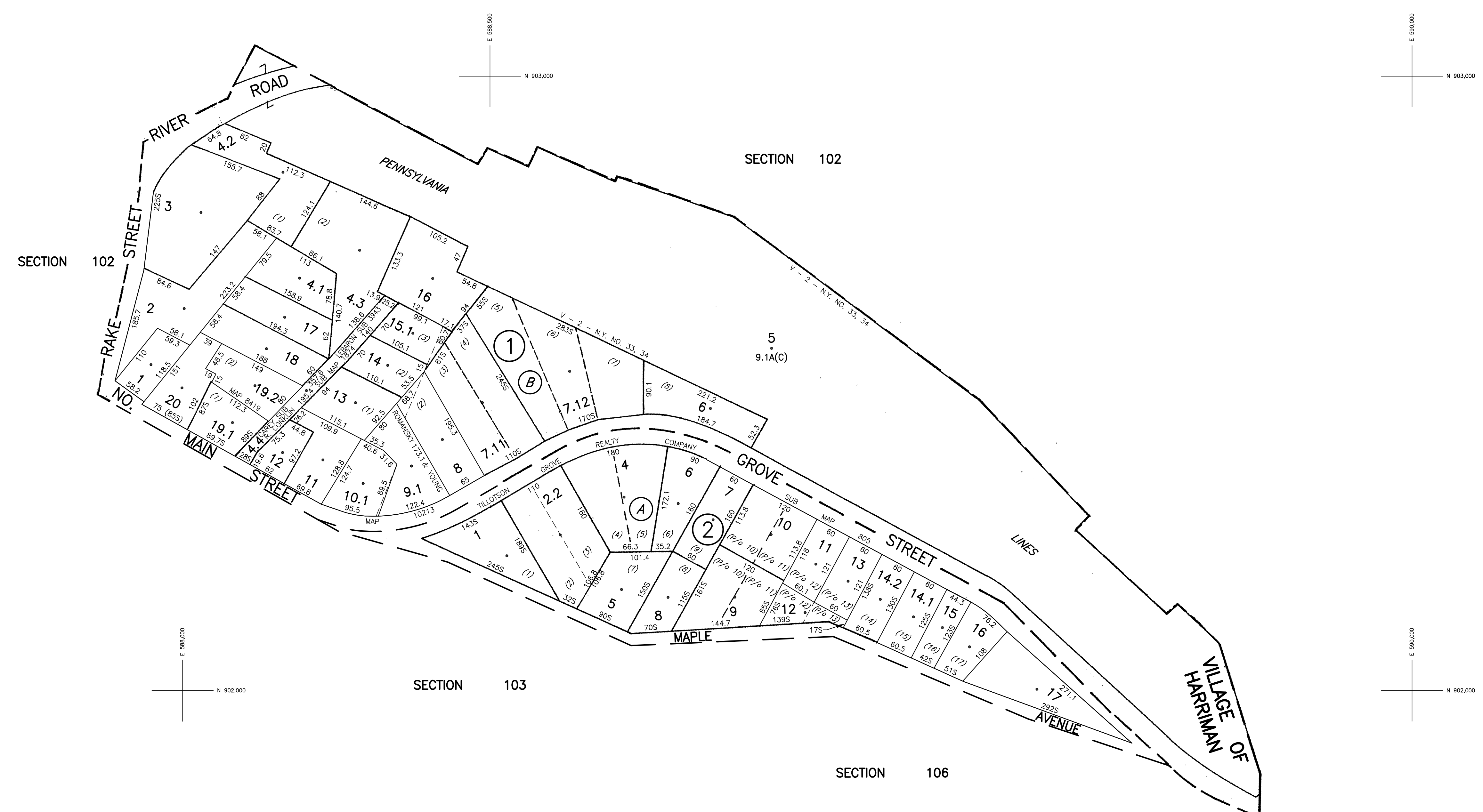

ALL MONROE JOINT FIRE DISTRICT

LEGEND

STATE OR COUNTY LINE	FILED PLAN LOT LINE	TAX MAP BLOCK NO. (4)	FILED PLAN BLOCK NO. (2) (4)
CITY TOWN OR VILLAGE	EASEMENT LINE	TAX MAP PARCEL NO. 32	FILED PLAN LOT NO. (3) or (P/o 2)
BLOCK OR SECTION LIMIT	MATCH LINE	AREAS (DEED) 11.1A or (CALCULATED) 11.6(C)	STATE HIGHWAYS N Y STATE HWY NO 17
SPECIAL DISTRICT LINE	WATER FEATURES	DIMENSIONS (DEED) 66 or (CALCULATED) 75S	COUNTY HIGHWAYS COUNTY ROAD NO 4
PROPERTY LINE	GRID COORDINATE/CENTROID	PORTION OF TAX LOT P/o 1-1-1	TOWN ROADS TOWN ROAD 1

ORANGE COUNTY—NEW YORK

Prepared by
Orange County Tax Map Department
124 Main Street, Goshen, N.Y. 10924
Phone 845.291.2498 Fax 845.291.2499

NOTICE
MAINTENANCE, ALTERATION, SALE OR DISTRIBUTION
OF ANY PORTION OF THE ORANGE COUNTY TAX
MAP IS PROHIBITED WITHOUT WRITTEN PERMISSION
OF THE O.C. REAL PROPERTY TAX SERVICE AGENCY

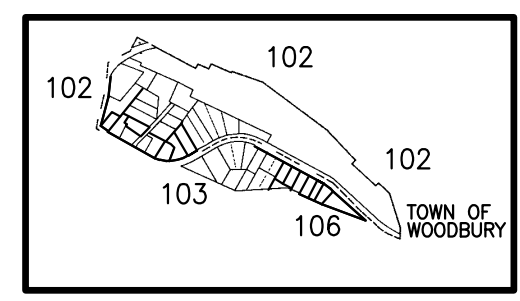

334003
VILLAGE OF HARRIMAN

Scale 1" = 100' Section No. 104

ADJOINING REFERENCE

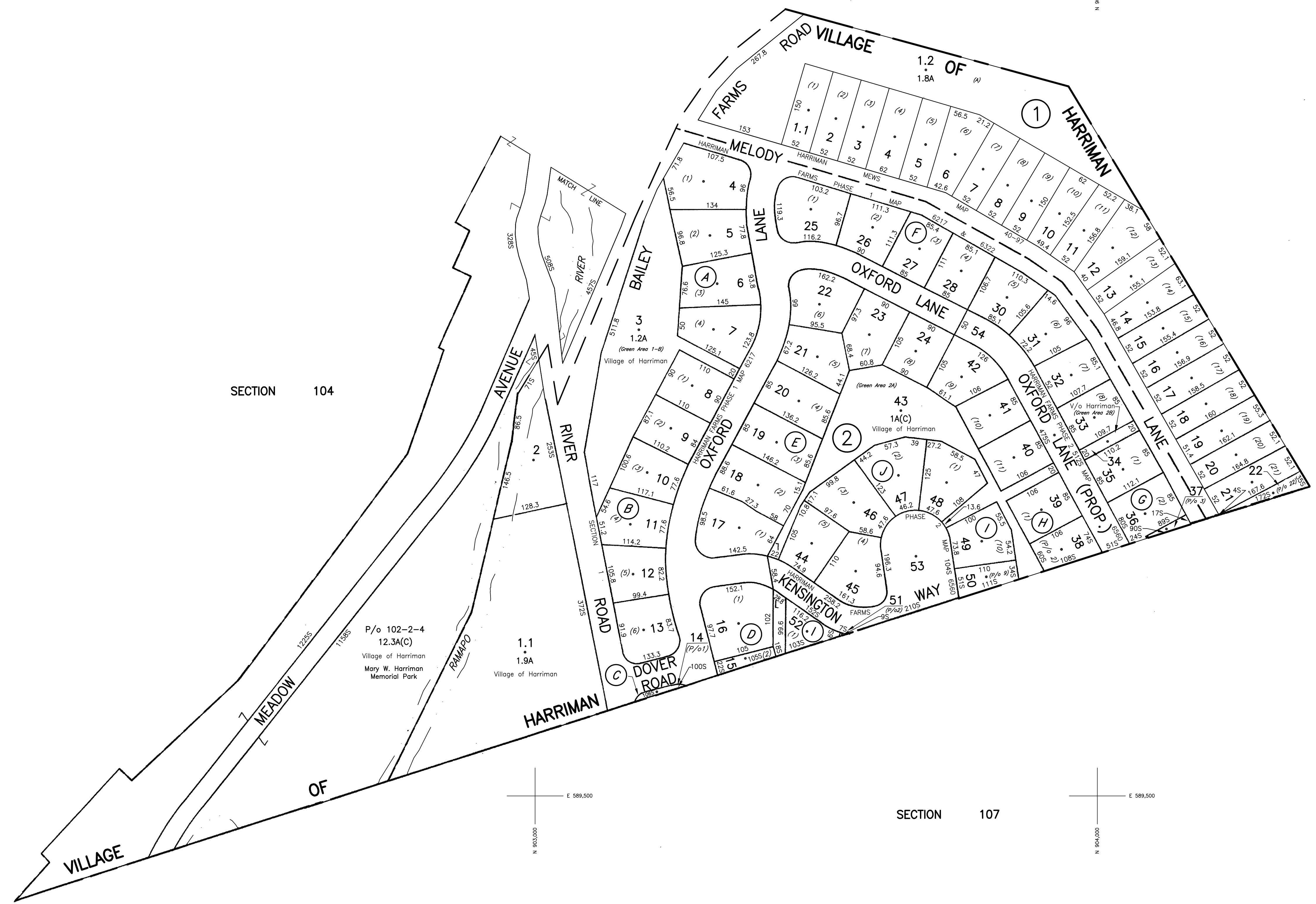
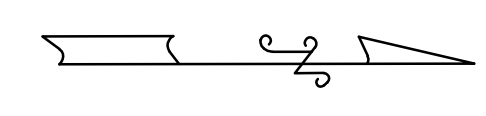
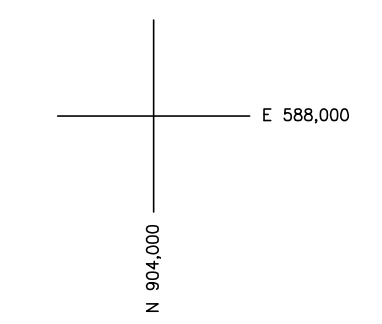
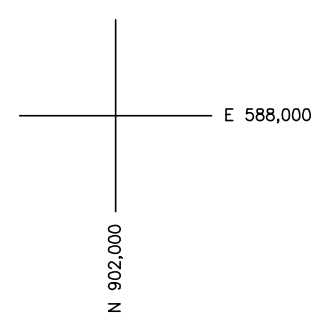

SECTION 104

SECTION 107

P/o 102-2-4
12.3A(C)
Village of Harriman
Mary W. Harriman
Memorial Park

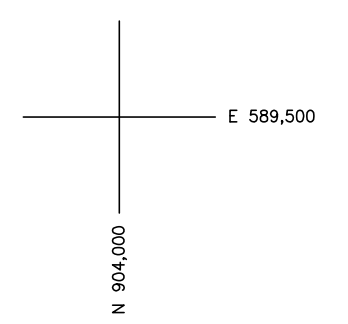
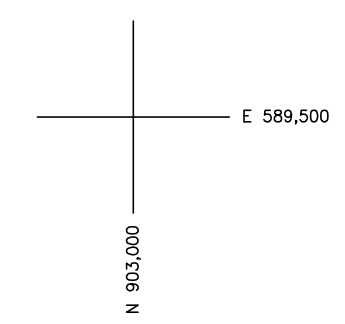

ALL MONROE JOINT FIRE DISTRICT

LEGEND

STATE OR COUNTY LINE	FILED PLAN LOT LINE	TAX MAP BLOCK NO. (4)	FILED PLAN BLOCK NO. (2) (4)
CITY TOWN OR VILLAGE	EASEMENT LINE	TAX MAP PARCEL NO. 32	FILED PLAN LOT NO. (3) or (P/o 2)
BLOCK OR SECTION LIMIT	MATCH LINE	AREAS (DEED) 11.1A or (CALCULATED) 11.6A(C)	STATE HIGHWAYS N Y STATE HWY NO 17
SPECIAL DISTRICT LINE	WATER FEATURES	DIMENSIONS (DEED) 66 or (CALCULATED) 75S	COUNTY HIGHWAYS COUNTY ROAD NO 4
PROPERTY LINE	GRID COORDINATE/CENTROID	PORTION OF TAX LOT P/o 1-1-1	TOWN ROADS TOWN ROAD 1

ORANGE COUNTY-NEW YORK

Prepared by
Orange County Tax Map Department
124 Main Street, Goshen, N.Y. 10924
Phone 845.291.2498 Fax 845.291.2499

NOTICE
MAINTENANCE, ALTERATION, SALE OR DISTRIBUTION
OF ANY PORTION OF THE ORANGE COUNTY TAX
MAP IS PROHIBITED WITHOUT WRITTEN PERMISSION
OF THE O.C. REAL PROPERTY TAX SERVICE AGENCY

NOT TO BE REPRODUCED FOR COMMERCIAL
PURPOSES FOR TAX PURPOSES ONLY
NOT TO BE USED FOR CONVEYANCE

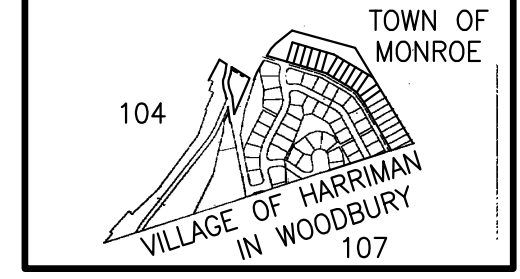

334003
VILLAGE OF HARRIMAN

Scale 1" = 100' Section No. 105

ADJOINING REFERENCE

REVISION
03/01/03
10/22/03
05/11/06
06/02/06
07/21/06
08/13/07
10/23/07
04/16/08
12/22/09
01/06/10

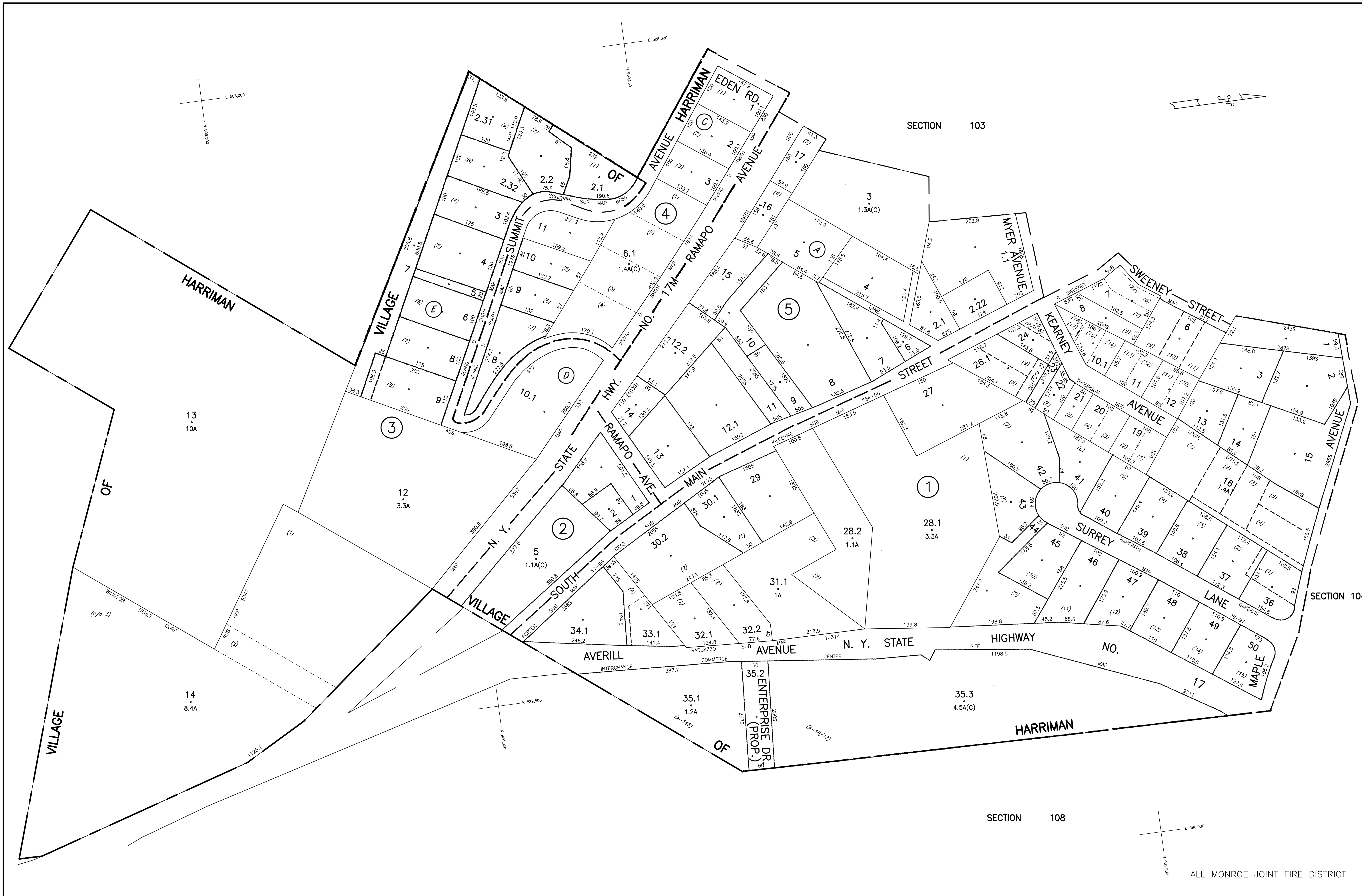

LEGEND

STATE OR COUNTY LINE	FILED PLAN LOT LINE	TAX MAP BLOCK NO. (4)	FILED PLAN BLOCK NO. (2) (4)
CITY TOWN OR VILLAGE	EASEMENT LINE	TAX MAP PARCEL NO. 32	FILED PLAN LOT NO. (3) or (P/O 2)
BLOCK OR SECTION LIMIT	MATCH LINE	AREAS (DEED) 11.1A or (CALCULATED) 11.6(C)	STATE HIGHWAYS N Y STATE HWY NO 17
SPECIAL DISTRICT LINE	WATER FEATURES	DIMENSIONS (DEED) 66 or (CALCULATED) 75S	COUNTY HIGHWAYS COUNTY ROAD NO 4
PROPERTY LINE	GRID COORDINATE/CENTROID	PORTION OF TAX LOT P/O 1-1-1	TOWN ROADS TOWN ROAD 1

ORANGE COUNTY—NEW YORK

Prepared by
Orange County Tax Map Department
124 Main Street, Goshen, N.Y. 10924
Phone 845.291.2498 Fax 845.291.2499

NOTICE
MAINTENANCE, ALTERATION, SALE OR DISTRIBUTION
OF ANY PORTION OF THE ORANGE COUNTY TAX
MAP IS PROHIBITED WITHOUT WRITTEN PERMISSION
OF THE O.C. REAL PROPERTY TAX SERVICE AGENCY

NOT TO BE REPRODUCED FOR COMMERCIAL
PURPOSES FOR TAX PURPOSES ONLY
NOT TO BE USED FOR CONVEYANCE

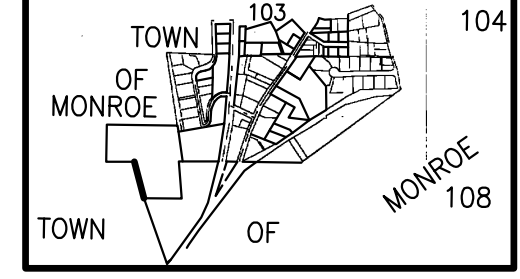

334003
VILLAGE OF HARRIMAN

Scale 1" = 100' Section No. 106

ADJOINING REFERENCE

REVISION
03/01/03
10/22/03
02/17/05
06/09/05
LR

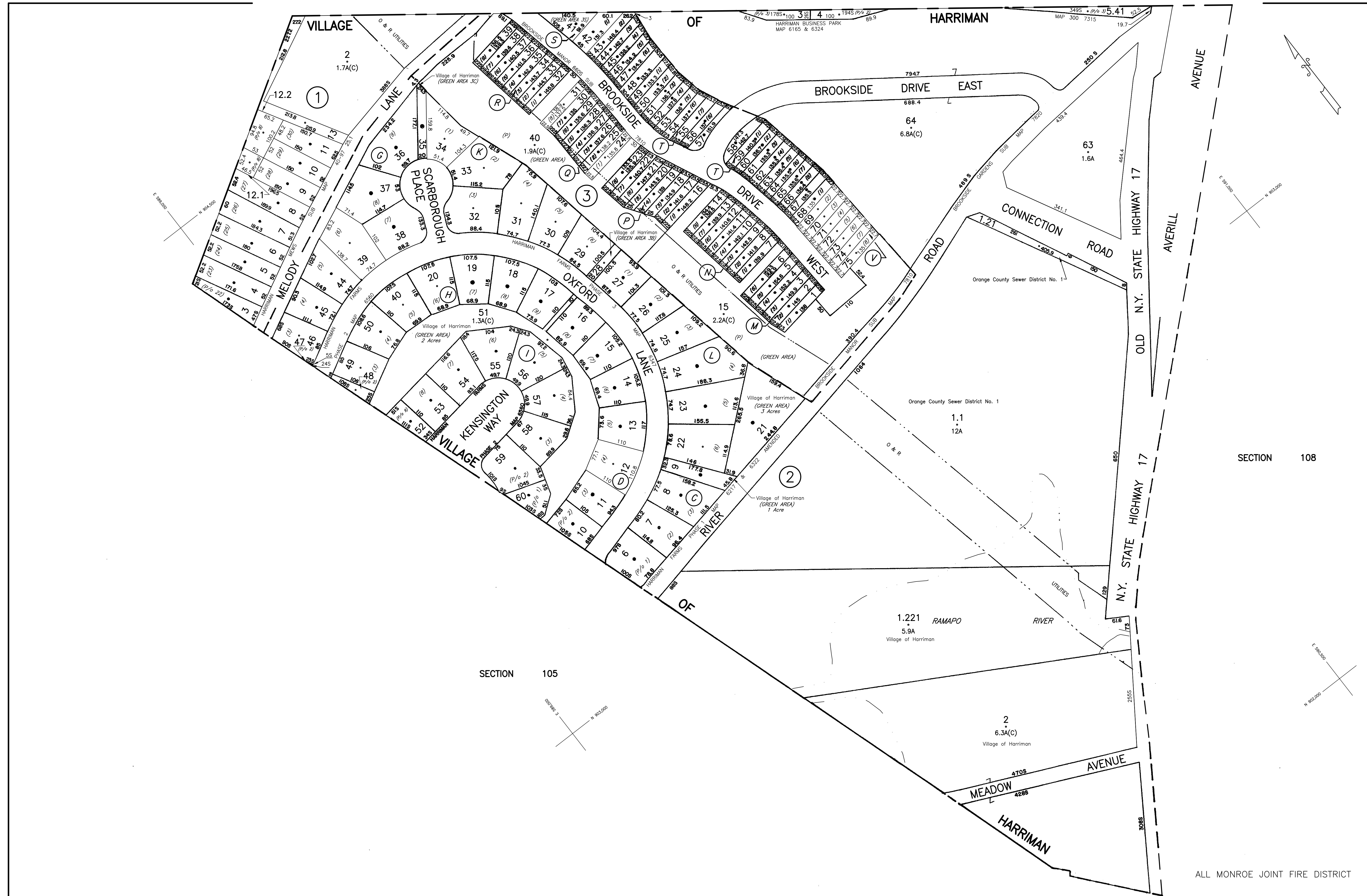

SECTION 108

SECTION 105

335801
VILLAGE OF HARRIMAN
 IN THE TOWN OF WOODBURY
 Scale 1" = 100' Section No. 107

LEGEND

STATE OR COUNTY LINE	FILED PLAN LOT LINE	TAX MAP BLOCK NO. (4)	FILED PLAN BLOCK NO. (2) (4)
CITY TOWN OR VILLAGE	EASEMENT LINE	TAX MAP PARCEL NO. 32	FILED PLAN LOT NO. (3) or (P/o 2)
BLOCK OR SECTION LIMIT	MATCH LINE	AREAS (DEED) 11.1A or (CALCULATED) 11.6(C)	STATE HIGHWAYS N Y STATE HWY NO 17
SPECIAL DISTRICT LINE	WATER FEATURES	DIMENSIONS (DEED) 66 or (CALCULATED) 75S	COUNTY HIGHWAYS COUNTY ROAD NO 4
PROPERTY LINE	GRID COORDINATE/CENTROID	PORTION OF TAX LOT P/o 1-1-1	TOWN ROADS TOWN ROAD 1

ORANGE COUNTY—NEW YORK

Prepared by
 Orange County Tax Map Department
 124 Main Street, Goshen, N.Y. 10924
 Phone 845.291.2498 Fax 845.291.2499

NOTICE
 MAINTENANCE, ALTERATION, SALE OR DISTRIBUTION
 OF ANY PORTION OF THE ORANGE COUNTY TAX
 MAP IS PROHIBITED WITHOUT WRITTEN PERMISSION
 OF THE O.C. REAL PROPERTY TAX SERVICE AGENCY

NOT TO BE REPRODUCED FOR COMMERCIAL
 PURPOSES FOR TAX PURPOSES ONLY
 NOT TO BE USED FOR CONVEYANCE

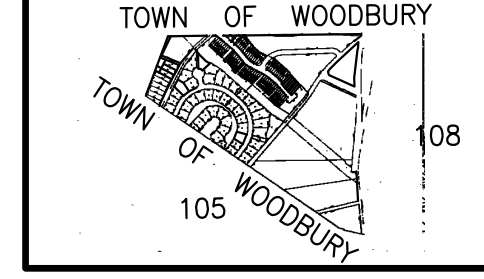

ADJOINING REFERENCE

REVISION
03/01/03
10/22/03
10/22/04
10/26/04

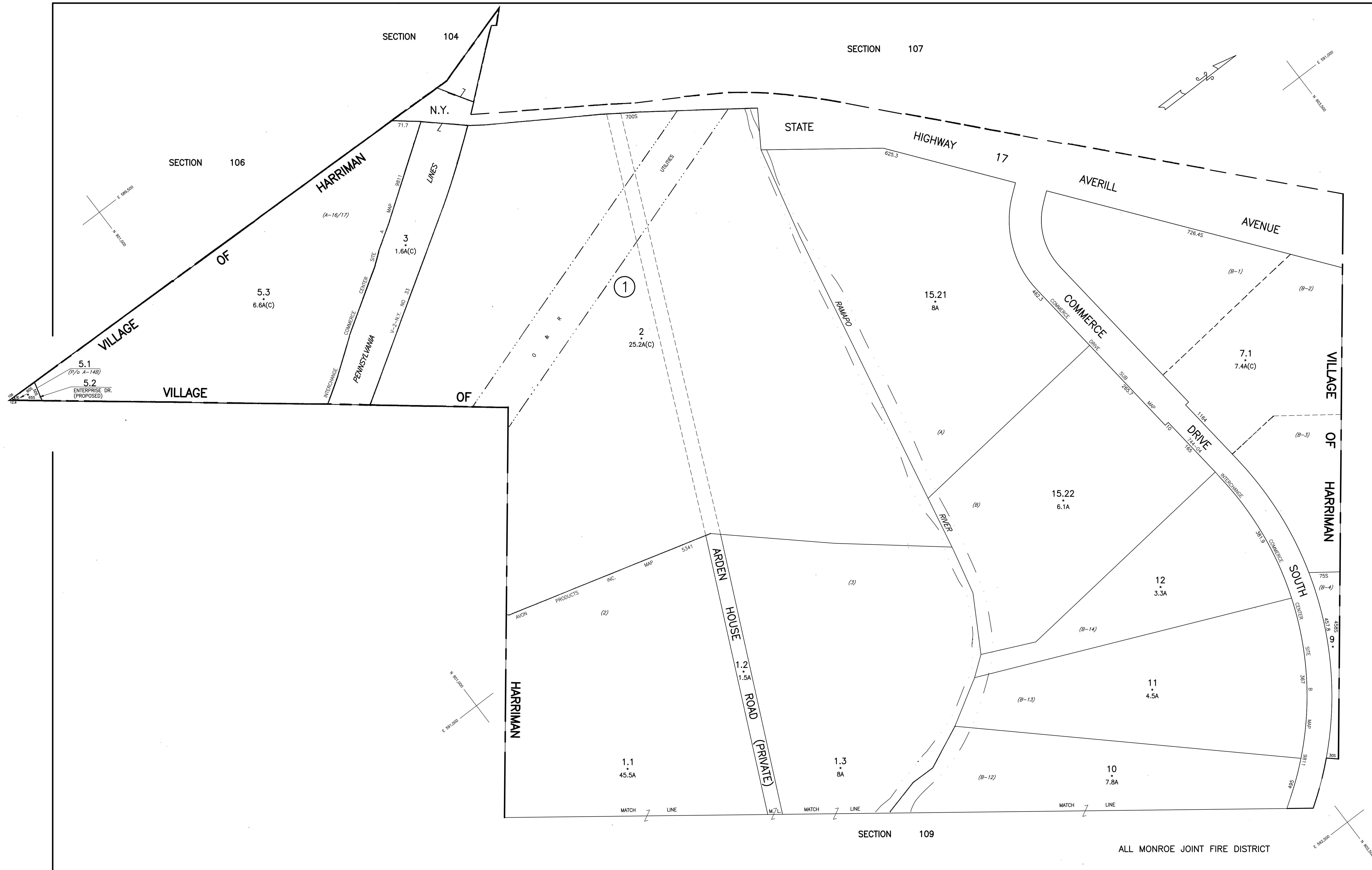

ALL MONROE JOINT FIRE DISTRICT

LEGEND

STATE OR COUNTY LINE	FILED PLAN LOT LINE	TAX MAP BLOCK NO. (4)	FILED PLAN BLOCK NO. (2) (4)
CITY TOWN OR VILLAGE	EASEMENT LINE	TAX MAP PARCEL NO. 32	FILED PLAN LOT NO. (3) or (P/o 2)
BLOCK OR SECTION LIMIT	MATCH LINE	AREAS (DEED) 11.1A or (CALCULATED) 11.6(C)	STATE HIGHWAYS N Y STATE HWY NO 17
SPECIAL DISTRICT LINE	WATER FEATURES	DIMENSIONS (DEED) 66 or (CALCULATED) 75S	COUNTY HIGHWAYS COUNTY ROAD NO 4
PROPERTY LINE	GRID COORDINATE/CENTROID	PORTION OF TAX LOT P/o 1-1-1	TOWN ROADS TOWN ROAD 1

ORANGE COUNTY-NEW YORK

Prepared by
Orange County Tax Map Department
124 Main Street, Goshen, N.Y. 10924
Phone 845.291.2498 Fax 845.291.2499

NOTICE
MAINTENANCE, ALTERATION, SALE OR DISTRIBUTION
OF ANY PORTION OF THE ORANGE COUNTY TAX
MAP IS PROHIBITED WITHOUT WRITTEN PERMISSION
OF THE O.C. REAL PROPERTY TAX SERVICE AGENCY

NOT TO BE REPRODUCED FOR COMMERCIAL
PURPOSES FOR TAX PURPOSES ONLY
NOT TO BE USED FOR CONVEYANCE

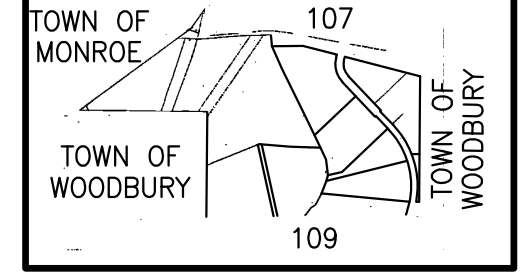

335801
VILLAGE OF HARRIMAN
IN THE TOWN OF WOODBURY
Scale 1" = 100' Section No. 108

REVISION
03/01/03
10/22/03
10/22/04
01/03/08
MB

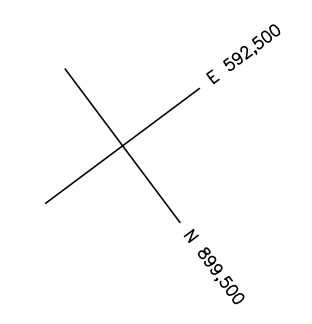
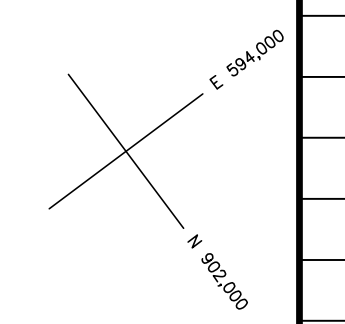
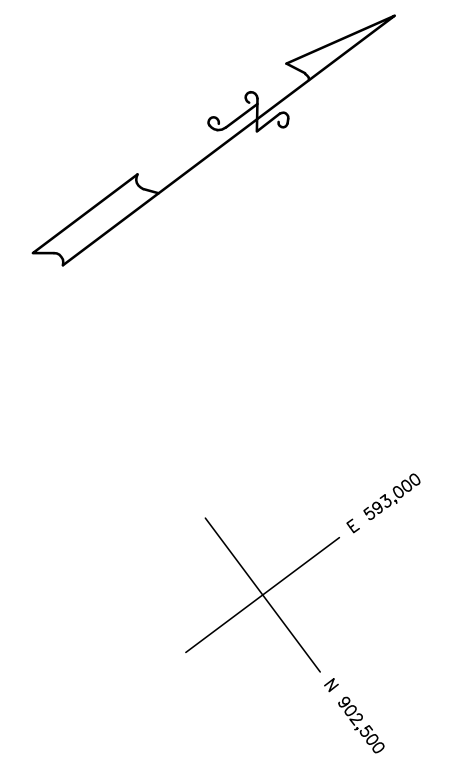
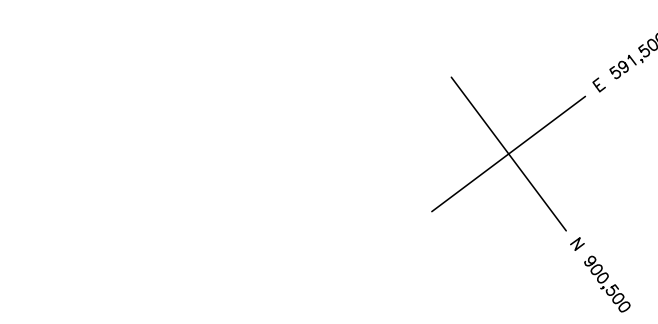
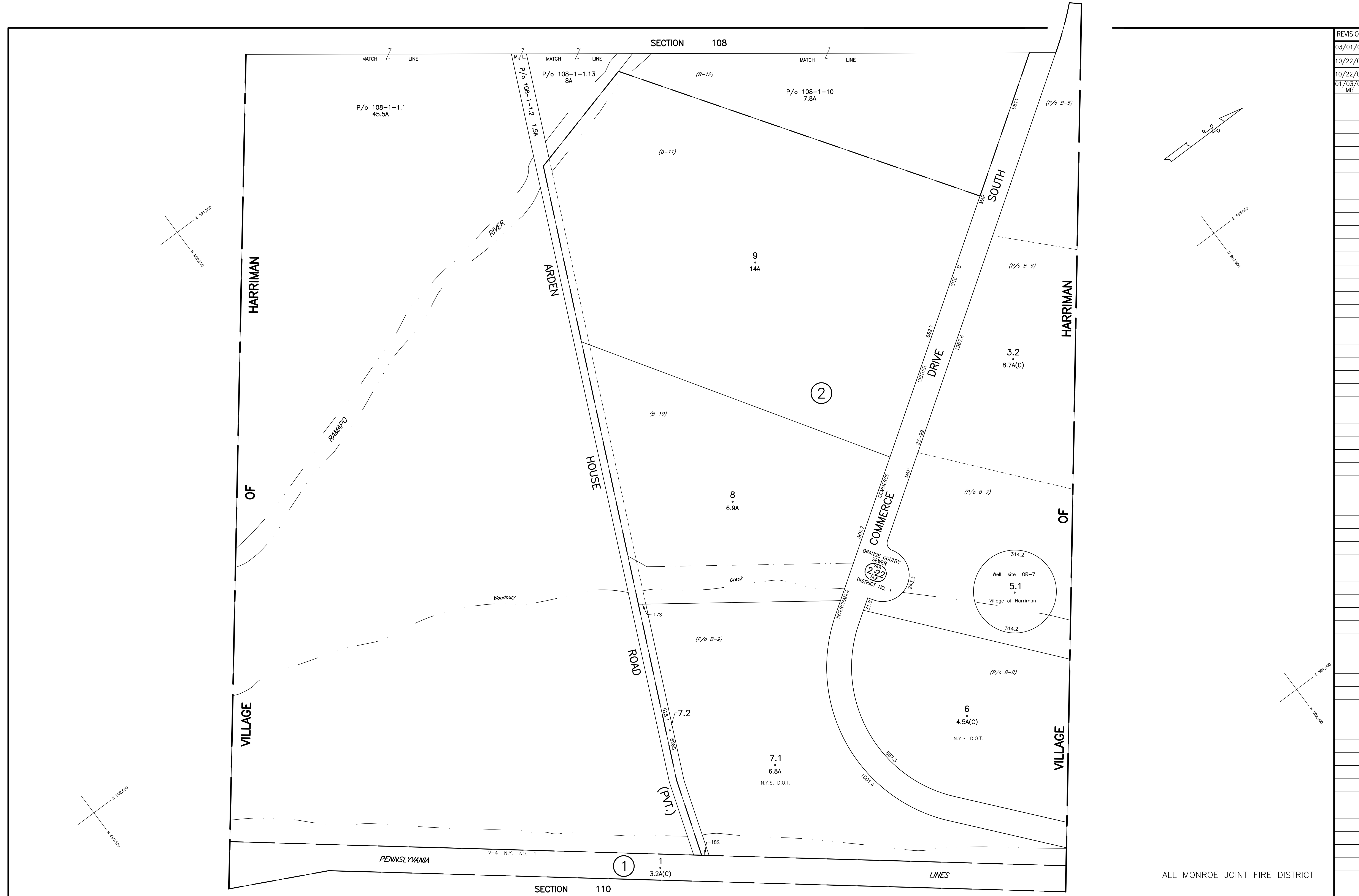

LEGEND

STATE OR COUNTY LINE	FILED PLAN LOT LINE	TAX MAP BLOCK NO. (4)	FILED PLAN BLOCK NO. (2) (4)
CITY TOWN OR VILLAGE	EASEMENT LINE	TAX MAP PARCEL NO. 32	FILED PLAN LOT NO. (3) or (P/o 2)
BLOCK OR SECTION LIMIT	MATCH LINE	AREAS (DEED) 11.1A or (CALCULATED) 11.6A(C)	STATE HIGHWAYS N Y STATE HWY NO 17
SPECIAL DISTRICT LINE	WATER FEATURES	DIMENSIONS (DEED) 66 or (CALCULATED) 75S	COUNTY HIGHWAYS COUNTY ROAD NO 4
PROPERTY LINE	GRID COORDINATE/CENTROID	PORTION OF TAX LOT P/o 1-1-1	TOWN ROADS TOWN ROAD 1

ORANGE COUNTY-NEW YORK

Prepared by
Orange County Tax Map Department
124 Main Street, Goshen, N.Y. 10924
Phone 845.291.2498 Fax 845.291.2499

NOTICE
MAINTENANCE, ALTERATION, SALE OR DISTRIBUTION
OF ANY PORTION OF THE ORANGE COUNTY TAX
MAP IS PROHIBITED WITHOUT WRITTEN PERMISSION
OF THE O.C. REAL PROPERTY TAX SERVICE AGENCY

NOT TO BE REPRODUCED FOR COMMERCIAL
PURPOSES FOR TAX PURPOSES ONLY
NOT TO BE USED FOR CONVEYANCE

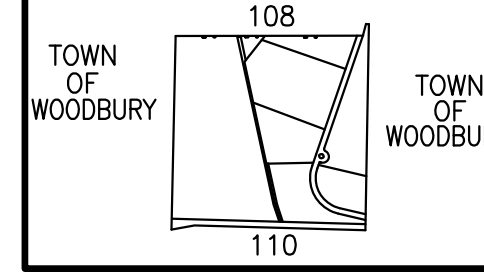

335801
VILLAGE OF HARRIMAN
IN THE TOWN OF WOODBURY
Scale 1" = 100' Section No. 109

ADJOINING REFERENCE

REVISION
03/01/03
10/22/03
01/20/05

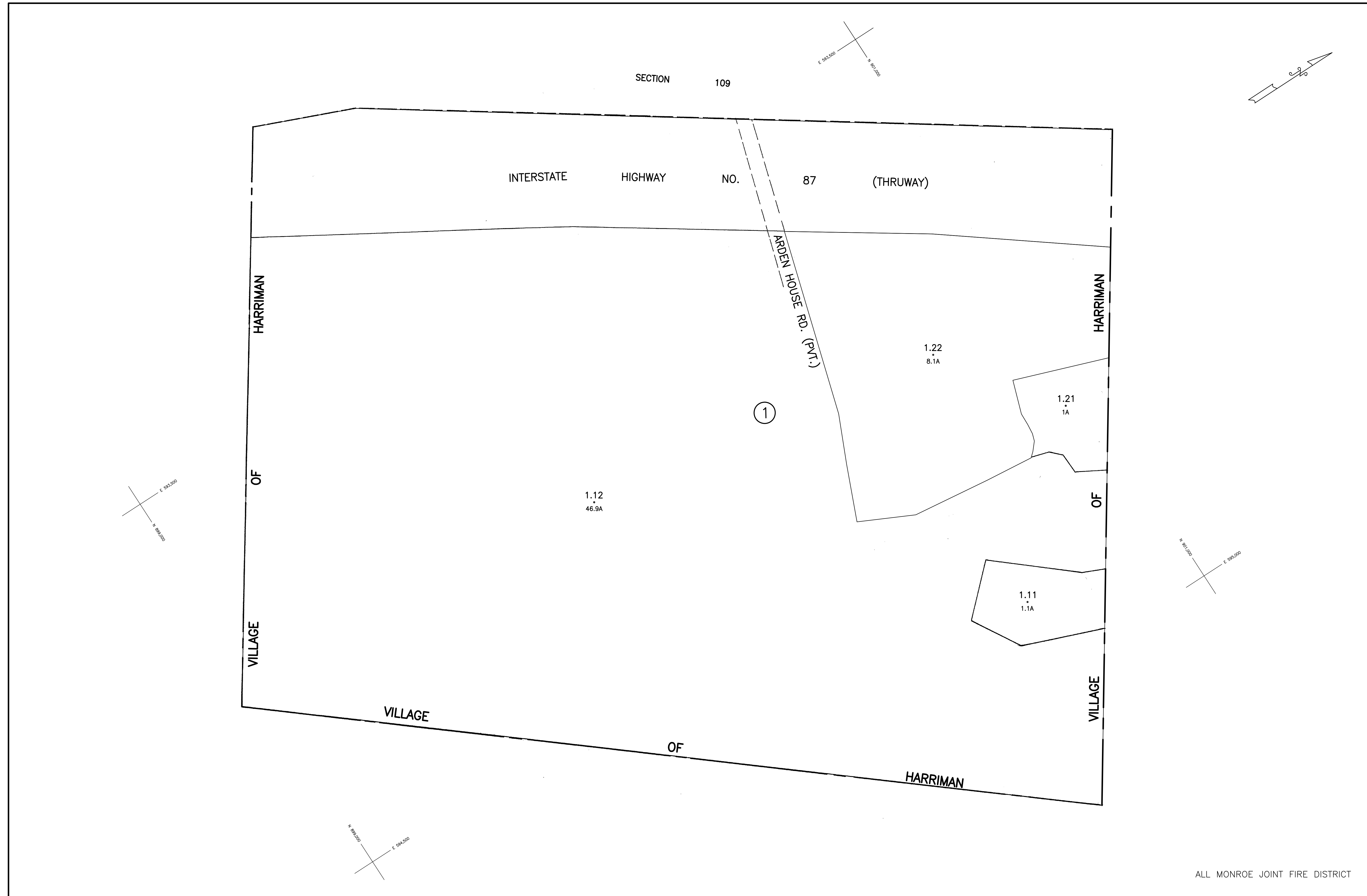

ALL MONROE JOINT FIRE DISTRICT

LEGEND			
STATE OR COUNTY LINE	FILED PLAN LOT LINE	TAX MAP BLOCK NO. (4)	FILED PLAN BLOCK NO. (2) (4)
CITY TOWN OR VILLAGE	EASEMENT LINE	TAX MAP PARCEL NO. 32	FILED PLAN LOT NO. (3) or (P/o 2)
BLOCK OR SECTION LIMIT	MATCH LINE	AREAS (DEED) 11.1A or (CALCULATED) 11.6(A)	STATE HIGHWAYS N Y STATE HWY NO 17
SPECIAL DISTRICT LINE	WATER FEATURES	DIMENSIONS (DEED) 66 or (CALCULATED) 75S	COUNTY HIGHWAYS COUNTY ROAD NO 4
PROPERTY LINE	GRID COORDINATE/CENTROID	PORTION OF TAX LOT P/o 1-1-1	TOWN ROADS TOWN ROAD 1

ORANGE COUNTY—NEW YORK

Prepared by
Orange County Tax Map Department
124 Main Street, Goshen, N.Y. 10924
Phone 845.291.2498 Fax 845.291.2499

NOTICE
MAINTENANCE, ALTERATION, SALE OR DISTRIBUTION
OF ANY PORTION OF THE ORANGE COUNTY TAX
MAP IS PROHIBITED WITHOUT WRITTEN PERMISSION
OF THE O.C. REAL PROPERTY TAX SERVICE AGENCY

NOT TO BE REPRODUCED FOR COMMERCIAL
PURPOSES FOR TAX PURPOSES ONLY
NOT TO BE USED FOR CONVEYANCE

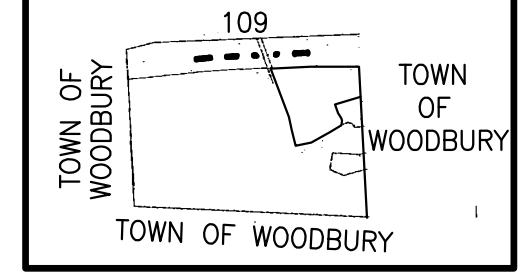

335801
VILLAGE OF HARRIMAN
IN THE TOWN OF WOODBURY
Scale 1" = 100' Section No. 110

BLOCK 1

LEXINGTON HILL CONDOMINIUM I
SECTION A & B
(12 BUILDINGS - 144 UNITS)
 A/K/A HARRIMAN CONDOMINIUM

MAP 6882, DECLARATION FILED IN LIBER 2320 PAGE 35 ON 01/23/85.
 EACH UNIT HAS A 1/144 PERCENTAGE OF COMMON INTEREST EXPRESSED AS
 A FRACTION OF 0.695%

BUILDING A			BUILDING B			BUILDING C			BUILDING D			BUILDING E			BUILDING F		
UNIT NUMBER	LOT NUMBER	SQUARE FEET	UNIT NUMBER	LOT NUMBER	SQUARE FEET	UNIT NUMBER	LOT NUMBER	SQUARE FEET	UNIT NUMBER	LOT NUMBER	SQUARE FEET	UNIT NUMBER	LOT NUMBER	SQUARE FEET	UNIT NUMBER	LOT NUMBER	SQUARE FEET
(1)	1.-1	950	(1)	1.-13	950	(1)	1.-25	950	(1)	1.-37	950	(1)	1.-49	950	(1)	1.-61	950
(2)	1.-2	950	(2)	1.-14	950	(2)	1.-26	950	(2)	1.-38	950	(2)	1.-50	950	(2)	1.-62	950
(3)	1.-3	964	(3)	1.-15	964	(3)	1.-27	964	(3)	1.-39	964	(3)	1.-51	964	(3)	1.-63	964
(4)	1.-4	964	(4)	1.-16	964	(4)	1.-28	964	(4)	1.-40	964	(4)	1.-52	964	(4)	1.-64	964
(5)	1.-5	964	(5)	1.-17	964	(5)	1.-29	964	(5)	1.-41	964	(5)	1.-53	964	(5)	1.-65	964
(6)	1.-6	964	(6)	1.-18	964	(6)	1.-30	964	(6)	1.-42	964	(6)	1.-54	964	(6)	1.-66	964
(7)	1.-7	950	(7)	1.-19	950	(7)	1.-31	950	(7)	1.-43	950	(7)	1.-55	950	(7)	1.-67	950
(8)	1.-8	950	(8)	1.-20	950	(8)	1.-32	950	(8)	1.-44	950	(8)	1.-56	950	(8)	1.-68	950
(9)	1.-9	964	(9)	1.-21	964	(9)	1.-33	964	(9)	1.-45	964	(9)	1.-57	964	(9)	1.-69	964
(10)	1.-10	964	(10)	1.-22	964	(10)	1.-34	964	(10)	1.-46	964	(10)	1.-58	964	(10)	1.-70	964
(11)	1.-11	964	(11)	1.-23	964	(11)	1.-35	964	(11)	1.-47	964	(11)	1.-59	964	(11)	1.-71	964
(12)	1.-12	964	(12)	1.-24	964	(12)	1.-36	964	(12)	1.-48	964	(12)	1.-60	964	(12)	1.-72	964

BUILDING G			BUILDING H			BUILDING I			BUILDING J			BUILDING K			BUILDING L		
UNIT NUMBER	LOT NUMBER	SQUARE FEET	UNIT NUMBER	LOT NUMBER	SQUARE FEET	UNIT NUMBER	LOT NUMBER	SQUARE FEET	UNIT NUMBER	LOT NUMBER	SQUARE FEET	UNIT NUMBER	LOT NUMBER	SQUARE FEET	UNIT NUMBER	LOT NUMBER	SQUARE FEET
(1)	1.-73	950	(1)	1.-85	950	(1)	1.-97	950	(1)	1.-109	950	(1)	1.-121	950	(1)	1.-133	950
(2)	1.-74	950	(2)	1.-86	950	(2)	1.-98	950	(2)	1.-110	950	(2)	1.-122	950	(2)	1.-134	950
(3)	1.-75	964	(3)	1.-87	964	(3)	1.-99	964	(3)	1.-111	964	(3)	1.-123	964	(3)	1.-135	964
(4)	1.-76	964	(4)	1.-88	964	(4)	1.-100	964	(4)	1.-112	964	(4)	1.-124	964	(4)	1.-136	964
(5)	1.-77	964	(5)	1.-89	964	(5)	1.-101	964	(5)	1.-113	964	(5)	1.-125	964	(5)	1.-137	964
(6)	1.-78	964	(6)	1.-90	964	(6)	1.-102	964	(6)	1.-114	964	(6)	1.-126	964	(6)	1.-138	964
(7)	1.-79	950	(7)	1.-91	950	(7)	1.-103	950	(7)	1.-115	950	(7)	1.-127	950	(7)	1.-139	950
(8)	1.-80	950	(8)	1.-92	950	(8)	1.-104	950	(8)	1.-116	950	(8)	1.-128	950	(8)	1.-140	950
(9)	1.-81	964	(9)	1.-93	964	(9)	1.-105	964	(9)	1.-117	964	(9)	1.-129	964	(9)	1.-141	964
(10)	1.-82	964	(10)	1.-94	964	(10)	1.-106	964	(10)	1.-118	964	(10)	1.-130	964	(10)	1.-142	964
(11)	1.-83	964	(11)	1.-95	964	(11)	1.-107	964	(11)	1.-119	964	(11)	1.-131	964	(11)	1.-143	964
(12)	1.-84	964	(12)	1.-96	964	(12)	1.-108	964	(12)	1.-120	964	(12)	1.-132	964	(12)	1.-144	964

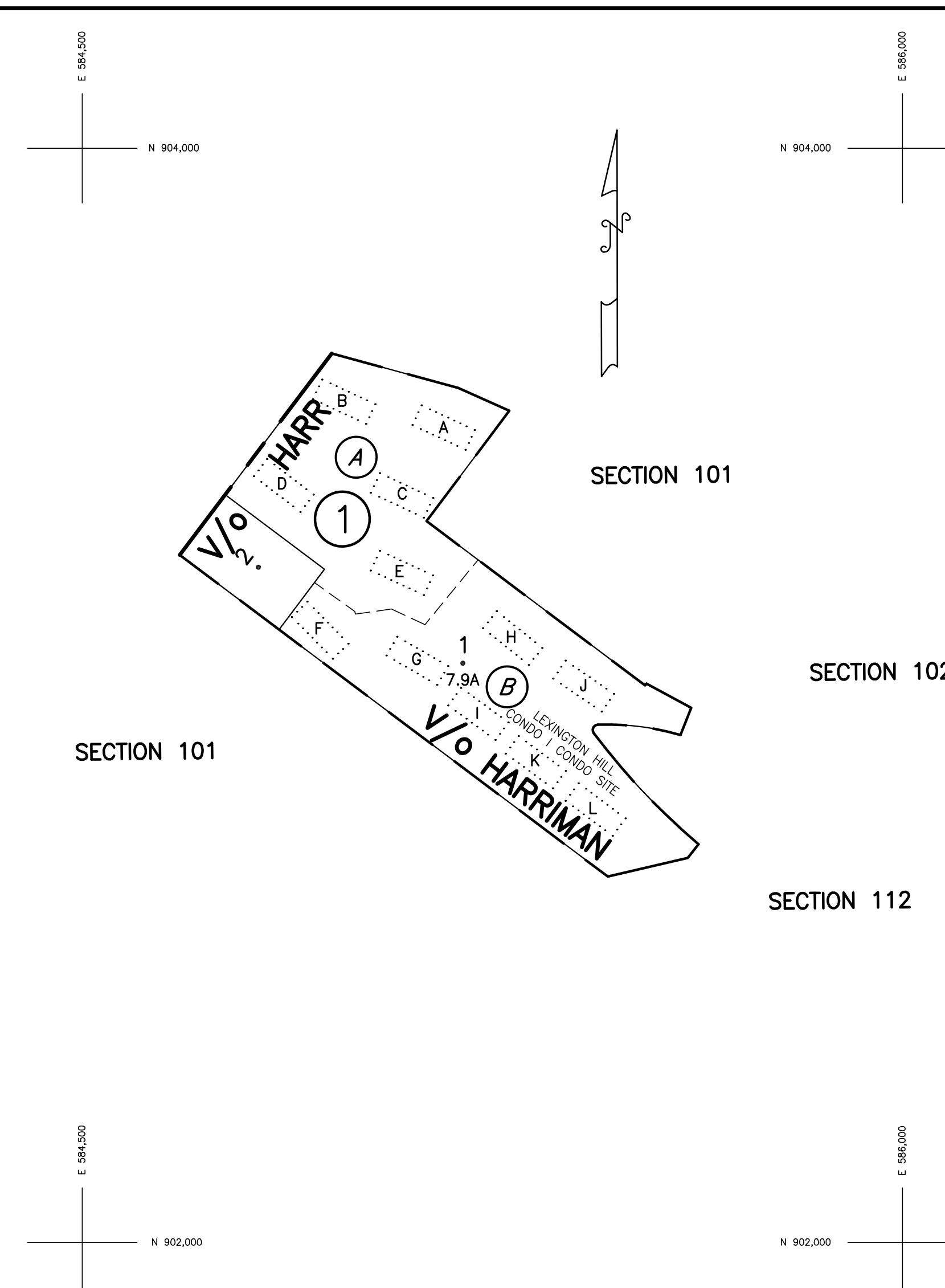

REVISION
03/01/03
10/22/03
07/22/05
SIG
10/02/09
LR

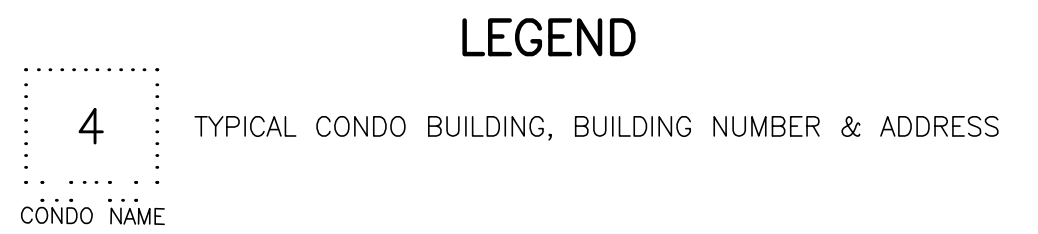

ALL MONROE JOINT FIRE DISTRICT

LEGEND

STATE OR COUNTY LINE	FILED PLAN LOT LINE	TAX MAP BLOCK NO. (4)	FILED PLAN BLOCK NO. (2) (4)
CITY TOWN OR VILLAGE	EASEMENT LINE	TAX MAP PARCEL NO. 32	FILED PLAN LOT NO. (3) or (P/o 2)
BLOCK OR SECTION LIMIT	MATCH LINE	AREAS (DEED) 11.1A or (CALCULATED) 11.6(C)	STATE HIGHWAYS N Y STATE HWY NO 17
SPECIAL DISTRICT LINE	WATER FEATURES	DIMENSIONS (DEED) 66 or (CALCULATED) 75S	COUNTY HIGHWAYS COUNTY ROAD NO 4
PROPERTY LINE	GRID COORDINATE/CENTROID	PORTION OF TAX LOT P/o 1-1-1	TOWN ROADS TOWN ROAD 1

ORANGE COUNTY-NEW YORK

Prepared by
 Orange County Tax Map Department
 124 Main Street, Goshen, N.Y. 10924
 Phone 845.291.2498 Fax 845.291.2499

NOTICE
 MAINTENANCE, ALTERATION, SALE OR DISTRIBUTION
 OF ANY PORTION OF THE ORANGE COUNTY TAX
 MAP IS PROHIBITED WITHOUT WRITTEN PERMISSION
 OF THE O.C. REAL PROPERTY TAX SERVICE AGENCY

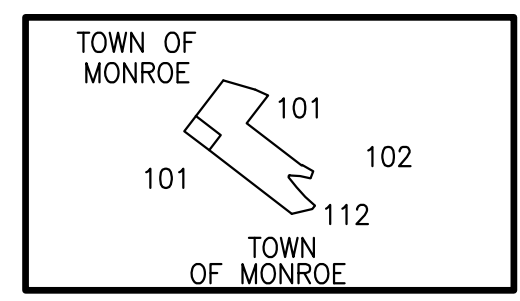

334003
VILLAGE OF HARRIMAN

Scale 1" = 200' Section No. 111

ADJOINING REFERENCE

BLOCK 1

LEXINGTON HILL CONDOMINIUM 2
SECTION C & D
(11 BUILDINGS - 132 UNITS)
 A/K/A HARRIMAN CONDOMINIUM

MAP 7280, DECLARATION FILED IN LIBER 2423 PAGE 278 ON 10/09/85.
 EACH UNIT HAS A 1/132 PERCENTAGE OF COMMON INTEREST EXPRESSED AS
 A FRACTION OF 0.7576%

BUILDING M			BUILDING N			BUILDING O			BUILDING P			BUILDING Q			BUILDING R		
UNIT NUMBER	LOT NUMBER	SQUARE FEET	UNIT NUMBER	LOT NUMBER	SQUARE FEET	UNIT NUMBER	LOT NUMBER	SQUARE FEET	UNIT NUMBER	LOT NUMBER	SQUARE FEET	UNIT NUMBER	LOT NUMBER	SQUARE FEET	UNIT NUMBER	LOT NUMBER	SQUARE FEET
(1)	1.-1	950	(1)	1.-13	950	(1)	1.-25	950	(1)	1.-37	950	(1)	1.-49	950	(1)	1.-61	950
(2)	1.-2	950	(2)	1.-14	950	(2)	1.-26	950	(2)	1.-38	950	(2)	1.-50	950	(2)	1.-62	950
(3)	1.-3	960	(3)	1.-15	960	(3)	1.-27	960	(3)	1.-39	960	(3)	1.-51	960	(3)	1.-63	960
(4)	1.-4	960	(4)	1.-16	960	(4)	1.-28	960	(4)	1.-40	960	(4)	1.-52	960	(4)	1.-64	960
(5)	1.-5	960	(5)	1.-17	960	(5)	1.-29	960	(5)	1.-41	960	(5)	1.-53	960	(5)	1.-65	960
(6)	1.-6	960	(6)	1.-18	960	(6)	1.-30	960	(6)	1.-42	960	(6)	1.-54	960	(6)	1.-66	960
(7)	1.-7	950	(7)	1.-19	950	(7)	1.-31	950	(7)	1.-43	950	(7)	1.-55	950	(7)	1.-67	950
(8)	1.-8	950	(8)	1.-20	950	(8)	1.-32	950	(8)	1.-44	950	(8)	1.-56	950	(8)	1.-68	950
(9)	1.-9	960	(9)	1.-21	960	(9)	1.-33	960	(9)	1.-45	960	(9)	1.-57	960	(9)	1.-69	960
(10)	1.-10	960	(10)	1.-22	960	(10)	1.-34	960	(10)	1.-46	960	(10)	1.-58	960	(10)	1.-70	960
(11)	1.-11	960	(11)	1.-23	960	(11)	1.-35	960	(11)	1.-47	960	(11)	1.-59	960	(11)	1.-71	960
(12)	1.-12	960	(12)	1.-24	960	(12)	1.-36	960	(12)	1.-48	960	(12)	1.-60	960	(12)	1.-72	960

BUILDING S			BUILDING T			BUILDING U			BUILDING V			BUILDING W		
UNIT NUMBER	LOT NUMBER	SQUARE FEET	UNIT NUMBER	LOT NUMBER	SQUARE FEET	UNIT NUMBER	LOT NUMBER	SQUARE FEET	UNIT NUMBER	LOT NUMBER	SQUARE FEET	UNIT NUMBER	LOT NUMBER	SQUARE FEET
(1)	1.-73	950	(1)	1.-85	950	(1)	1.-97	950	(1)	1.-109	950	(1)	1.-121	950
(2)	1.-74	950	(2)	1.-86	950	(2)	1.-98	950	(2)	1.-110	950	(2)	1.-122	950
(3)	1.-75	960	(3)	1.-87	960	(3)	1.-99	960	(3)	1.-111	960	(3)	1.-123	960
(4)	1.-76	960	(4)	1.-88	960	(4)	1.-100	960	(4)	1.-112	960	(4)	1.-124	960
(5)	1.-77	960	(5)	1.-89	960	(5)	1.-101	960	(5)	1.-113	960	(5)	1.-125	960
(6)	1.-78	960	(6)	1.-90	960	(6)	1.-102	960	(6)	1.-114	960	(6)	1.-126	960
(7)	1.-79	950	(7)	1.-91	950	(7)	1.-103	950	(7)	1.-115	950	(7)	1.-127	950
(8)	1.-80	950	(8)	1.-92	950	(8)	1.-104	950	(8)	1.-116	950	(8)	1.-128	950
(9)	1.-81	960	(9)	1.-93	960	(9)	1.-105	960	(9)	1.-117	960	(9)	1.-129	960
(10)	1.-82	960	(10)	1.-94	960	(10)	1.-106	960	(10)	1.-118	960	(10)	1.-130	960
(11)	1.-83	960	(11)	1.-95	960	(11)	1.-107	960	(11)	1.-119	960	(11)	1.-131	960
(12)	1.-84	960	(12)	1.-96	960	(12)	1.-108	960	(12)	1.-120	960	(12)	1.-132	960

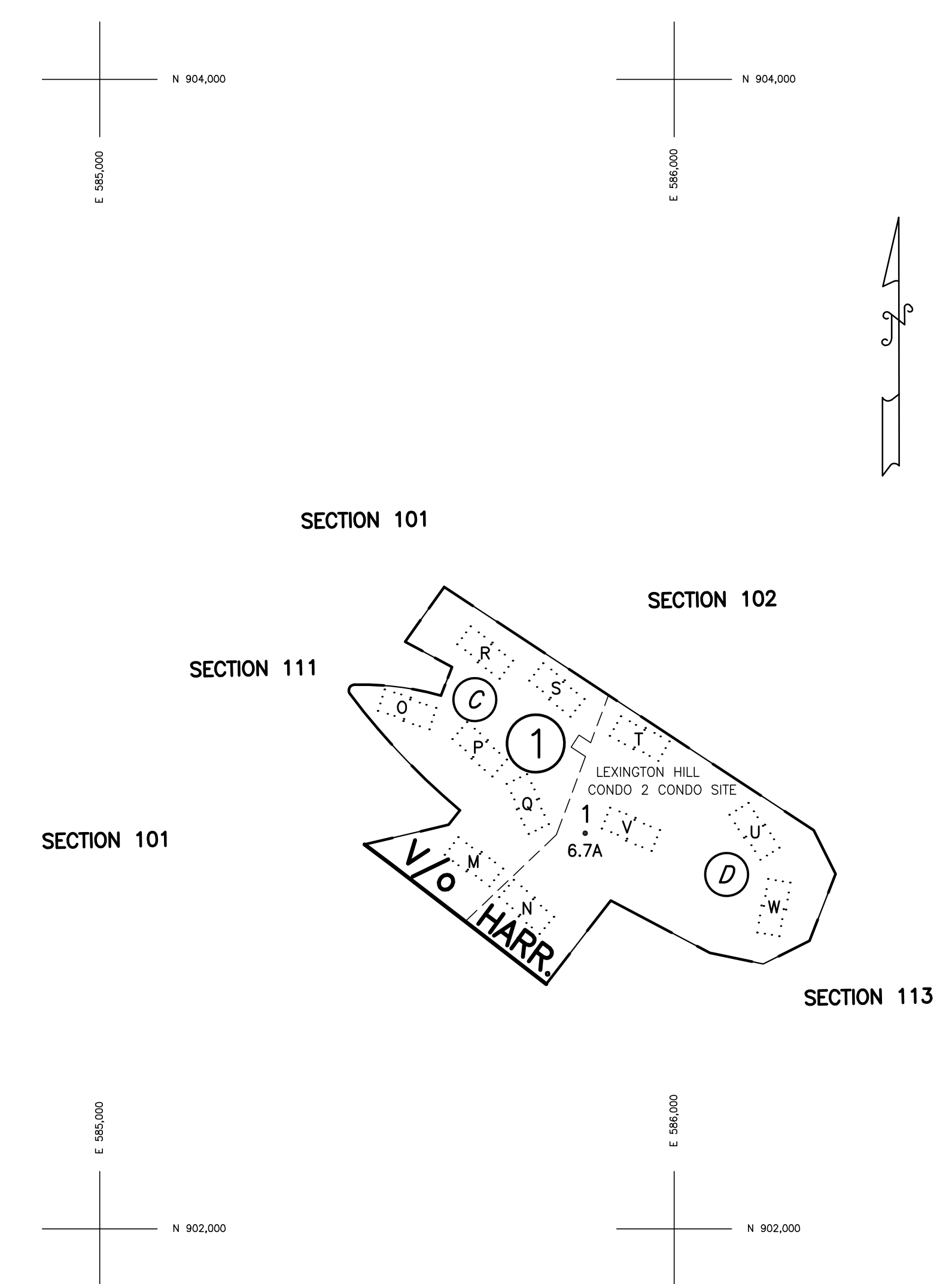

REVISION
03/01/03
10/22/03
07/22/05
SIG
10/07/09
LR

LEGEND

ALL MONROE JOINT FIRE DISTRICT

4 TYPICAL CONDO BUILDING, BUILDING NUMBER & ADDRESS
 CONDO NAME

LEGEND		TAX MAP BLOCK NO. (4)	FILED PLAN BLOCK NO. (2) (4)
STATE OR COUNTY LINE	FILED PLAN LOT LINE	TAX MAP PARCEL NO. 32	FILED PLAN LOT NO. (3) or (P/o 2)
CITY TOWN OR VILLAGE	EASEMENT LINE	AREAS (DEED) 11.1A or (CALCULATED) 11.6A(C)	STATE HIGHWAYS N Y STATE HWY NO 17
BLOCK OR SECTION LIMIT	MATCH LINE	DIMENSIONS (DEED) 66 or (CALCULATED) 75S	COUNTY HIGHWAYS COUNTY ROAD NO 4
SPECIAL DISTRICT LINE	WATER FEATURES	PORTION OF TAX LOT P/o 1-1-1	TOWN ROADS TOWN ROAD 1
PROPERTY LINE	GRID COORDINATE/CENTROID		

ORANGE COUNTY-NEW YORK

Prepared by
 Orange County Tax Map Department
 124 Main Street, Goshen, N.Y. 10924
 Phone 845.291.2498 Fax 845.291.2499

NOTICE
 MAINTENANCE, ALTERATION, SALE OR DISTRIBUTION
 OF ANY PORTION OF THE ORANGE COUNTY TAX
 MAP IS PROHIBITED WITHOUT WRITTEN PERMISSION
 OF THE O.C. REAL PROPERTY TAX SERVICE AGENCY

NOT TO BE REPRODUCED FOR COMMERCIAL
 PURPOSES FOR TAX PURPOSES ONLY
 NOT TO BE USED FOR CONVEYANCE

334003
VILLAGE OF HARRIMAN

Scale 1" = 200' Section No. 112

ADJOINING REFERENCE

